

Laminar **Flow** Units



Front view standard model LFU-1

High Quality
Rapid Delivery
Customized design
Competative pricing

Powered by  **Cleanrooms**



Welcome

ProCleanroom, active as official partner and representation of Connect2Cleanrooms Ltd., specializes in modular cleanroom solutions & downflow cabinets. It is our common goal to exceed our customer's expectations by providing a reliable, high-quality product with a first class service and on-going customer support.

Our project engineers are experts in assessing and managing client's needs and with in-house consultancy, CAD facilities, installation and validation engineers and end user training we offer everything you would need for a comprehensive turnkey service, from concept to completion From Blue Chip companies to small start ups; we have the solution for you.



Example: custom design 2000 mm wide

Downflow solutions

The various down flow structures are intended for organisations that need to create a down flow environment that achieve the relevant quality standard to an acceptable time frame and budget !

The laminar flow hoods provide an economical, versatile solution to clean manufacturing, inspection & repair requirements in various areas of operation including plastics processing, medical device assembly, food manufacture, aerospace, electronics and many other industries.

Choose between the standard model LFU-1 or a custom design for maximum flexibility in both dimensions and materials used.

High quality design

The Connect2Cleanrooms clean enclosures are well designed, portable and easy to assemble/disassemble. They come with either a powder coated mild steel or stainless steel frame, combined with transparent PETg or RAL coated metal panels. Air filtering is offered through variable speed controlled HEPA or ULPA fan filter units.

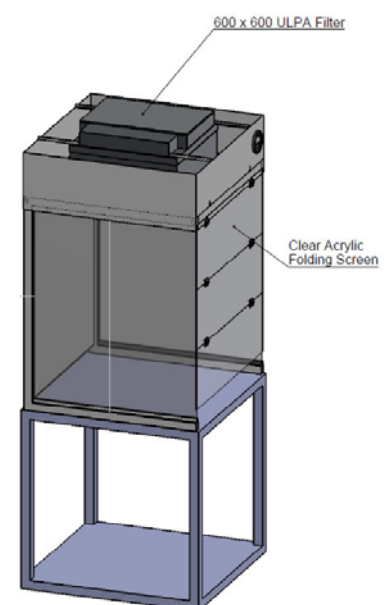

Example: custom design 1 x 1 x 1.2m stainless steel frame on stainless steel bench



Standard models LFU-1 & LFU-2

These bench mounted ISO5 laminar flow hoods are available at attractive price levels and quick delivery.

A very high air change rate and positive pressure is offered through HEPA or ULPA filter system at ca. 0.45 m/s face velocity. Clear PETg side and front panels allow for maximum ambient light to enter the working space.

LFU-1 & LFU-2 product specifications:

External size (in mm): LFU1- 1330 (W) x 667 (D) x 1075 (H)
 LFU2 - 850 (W) x 667 (D) x 1075 (H)

Internal size (in mm): LFU1 - 1175 (W) x 568 (D) x 750 (H)
 LFU2 - 700 (W) x 568 (D) x 750 (H)

Construction: powder coated steel frame with clear acrylic panels

Intake filter: recyclable 30ppi snap-in prefilter with aluminium frame

HEPA fan filter: H14 1200 x 600 or 600 x 600 (noise level 48dB)

Fan control: 3 step variable

Air velocity: 0.45 m/s (+/- 20%)

Magnahelic gauge: 0-250 Pa to monitor filter pressure

Electrical: 230 VAC, 50 Hz, 200W, single phase

Warranty: 2 years

Accessories include lights, ULPA filter and stainless steel support benches.

Custom design

In order to meet your specific needs, we offer customized design by in-house engineering & CAD design. Changes to standard models or fully tailored designs to fit your needs: we have the solution for you!

Short delivery

Standard models are either available from stock or have a 2 weeks maximum leadtime after receipt of order.

Long leadtime for custom designs? No! even a customized design can be delivered to you in only 2 – 3 weeks after design approval.

- ❖ ISO 14644 – part 1 Class 5 (Fed. class 100)
- ❖ Folding or sliding door
- ❖ Bench mount or free standing
- ❖ Pressure gauge
- ❖ Variable speed control
- ❖ Powder coated or stainless steel frame
- ❖ PETg transparent or coated metal panels

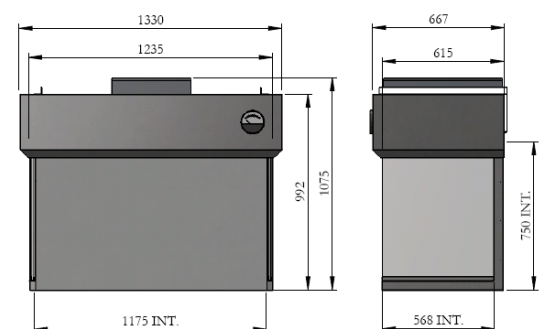

Dimensions model LFU-1

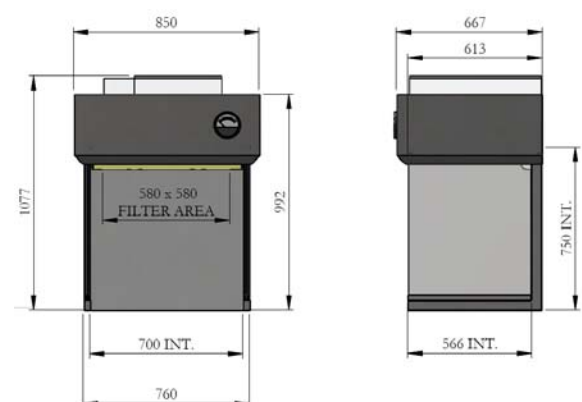

Dimensions model LFU-2



Typical applications & markets:

- ❖ Nano-Technologies & Photonics
- ❖ Semiconductor / Electronics
- ❖ Manufacturing
- ❖ Food Contact
- ❖ Research/Academia
- ❖ Healthcare
- ❖ Life Science
- ❖ Pharmaceutical
- ❖ Defense & Aerospace

Related products:

- ❖ Modular cleanroom solutions – softwall or solid wall cleanrooms
- ❖ Containment Units – tailored isolation cleanrooms for pharma and chemical applications

Check our website for additional information

© copyright 2010 – ProCleanroom, a Fergutec b.v. company
images and drawings are property of Connect2Cleanrooms Ltd.

www.procleanroom.eu



Heistraat 64
5554 ER Valkenswaard
The Netherlands

Tel. +31 (0)40 20 469 31
Fax. +31 (0)40 20 139 81

www.procleanroom.eu
info@procleanroom.eu

talk to us! +31 (0)40 20 46931